

Eidolon Hand Held Slit Lamp Model 510L

The ultraportable Model 510L is a popular diagnostic instrument for examination of anterior segment structures and ocular abnormalities. Its patented optical system produces a high-brightness, continuously adjustable slit image. Ideal wherever a tabletop slit lamp is impractical or unavailable, the Model 510L is particularly suited for pediatric and geriatric settings, emergency departments, screenings, ward rounds, bedside examinations, post-op evaluations, and mission work.

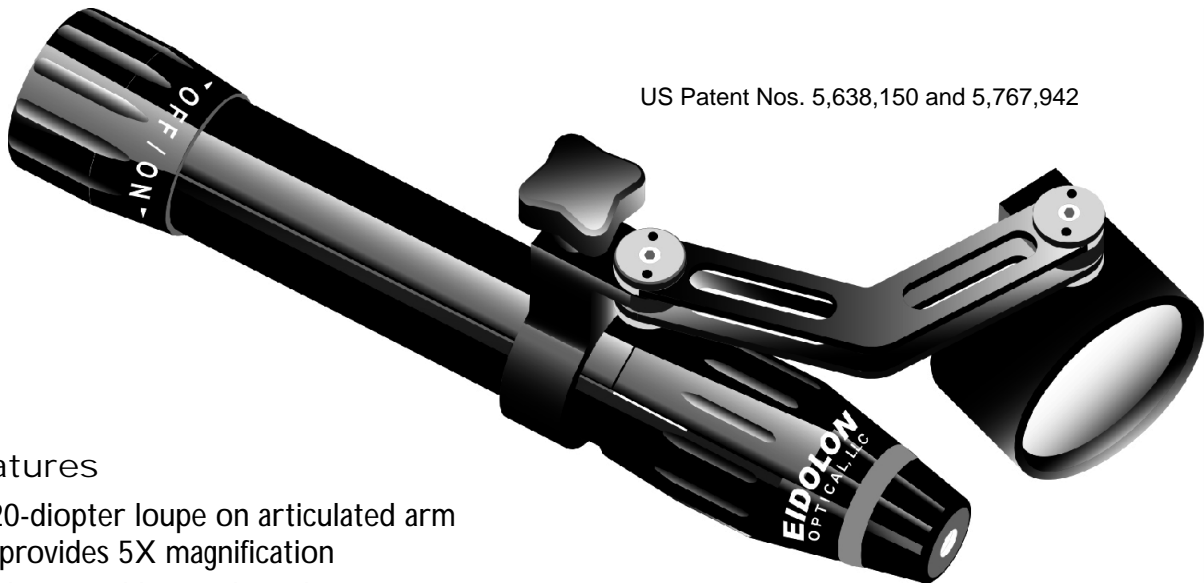

US Patent Nos. 5,638,150 and 5,767,942

Features

- 1 20-diopter loupe on articulated arm provides 5X magnification
- 1 Ultraportable, weighs only a few ounces
- 1 Wide field of view, outstanding image quality
- 1 Operates for hours on standard alkaline AA batteries
- 1 Gravity-independent for use at bedside
- 1 New ballistic nylon soft pouch case included
- 1 Unconditional 5-year guarantee
- 1 Made in USA

\$495.00

Accessories

- 1 Optional cobalt blue filter for examinations with fluorescein
- 1 High-resolution Digital Camera with Eidolon Adapter
- 1 Hard-shell case

Prices effective January 2008.

EIDOLON
O P T I C A L, L L C

www.slitlamp.com

3 Erie Drive Natick, MA 01760 USA tel: (508) 651-0015 / fax: (508) 651-0613