

New for 2004

# Eidolon® Hand Held Slit Lamp Model 510LS (Loupe System)

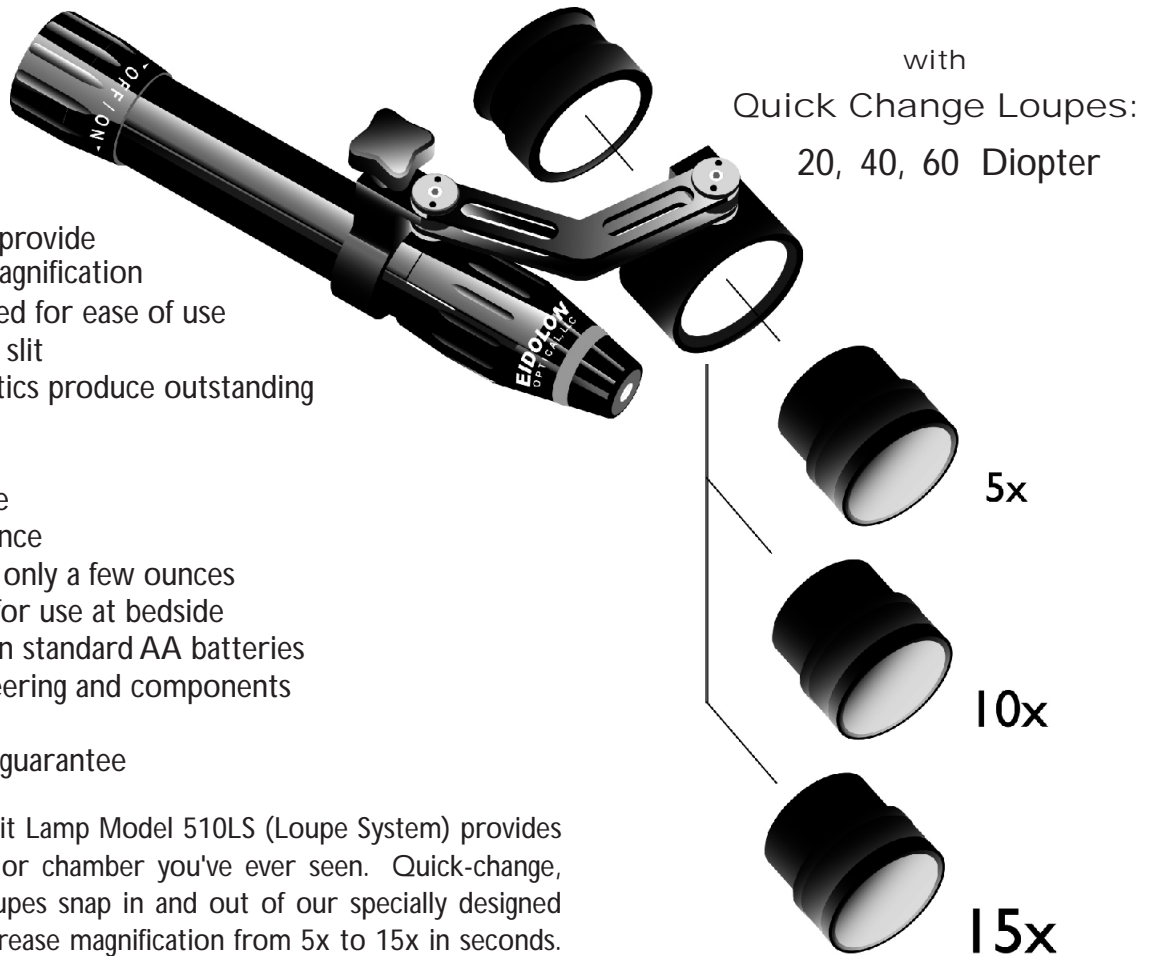

## Features

- 1 Quick-change loupes provide 20D, 40D, and 60D magnification
- 1 Loupes are color-coded for ease of use
- 1 Patented variable size slit
- 1 Precisely designed optics produce outstanding image quality
- 1 Wide field of view
- 1 Long working distance
- 1 Exceptional performance
- 1 Ultraportable, weighs only a few ounces
- 1 Gravity-independent for use at bedside
- 1 Operates for hours on standard AA batteries
- 1 Highest quality engineering and components
- 1 Made in USA
- 1 Unconditional 5-year guarantee

Eidolon's new Hand Held Slit Lamp Model 510LS (Loupe System) provides the best view of the anterior chamber you've ever seen. Quick-change, distinctively color-coded loupes snap in and out of our specially designed housing, enabling you to increase magnification from 5x to 15x in seconds. The Model 510LS comes standard with 20D (5x) and 40D (10x) loupes. A 60D (15x) loupe is available as an option.

The Model 510LS incorporates all the features of the popular original Model 510L. Ideal whenever a conventional slit lamp is impractical or unavailable, the Model 510LS, like the Model 510L, is particularly suited for pediatric and geriatric settings, emergency departments, screenings, ward rounds, operating rooms, post-op evaluations, and mission work. Its patented optical system produces a high-brightness, continuously adjustable slit image with a wide field of view. You can easily perform the most complete and thorough examination possible of the eye's anterior chamber, observing anatomical details of the cornea, lens, and iris, as well as cell and flare, and ocular trauma or abnormalities. Ergonomic and durable, the 510L series is gravity-independent for bedside use. It carries a 5-year unconditional guarantee.

Model 510LS Special Introductory Price: \$695.00

## Options:

- 60D (15x) Loupe: \$275.00
- Hardshell Travel Case: \$50.00

**EIDOLON**  
O P T I C A L, L L C

[www.slitlamp.com](http://www.slitlamp.com)

3 Erie Drive Natick, MA 01760 USA tel: (508) 651-0015 / fax: (508) 651-0613